



TEXAS ELECTRONICS INC.

AIR POLLUTION CONTROL SYSTEMS
2125 MADISON AVE.
MONTREAL, QUEBEC H4B 2T2
TEL:(514) 842-4431 FAX (514) 842-8641

MISTAIR 1.5-MV95

TITLE	MISTAIR 1.5-MV95		
DATE	MARCH 2004	DRAWN: M.F.	APPROVAL:
SCALE	NONE	CHECKED BY: M.S.	DRAWING NO:

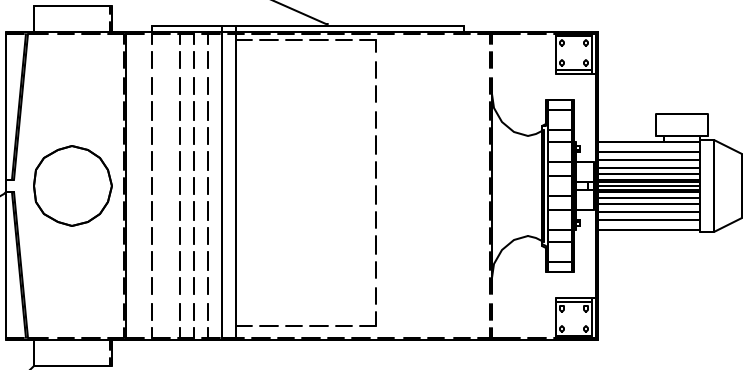
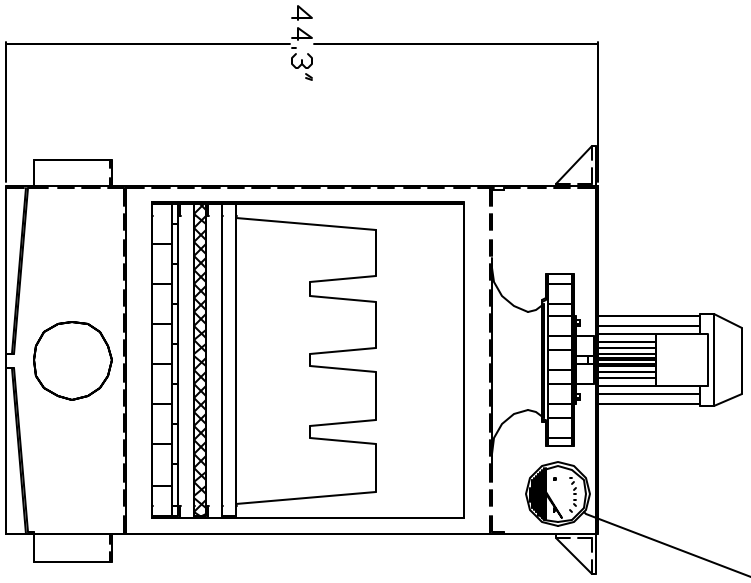
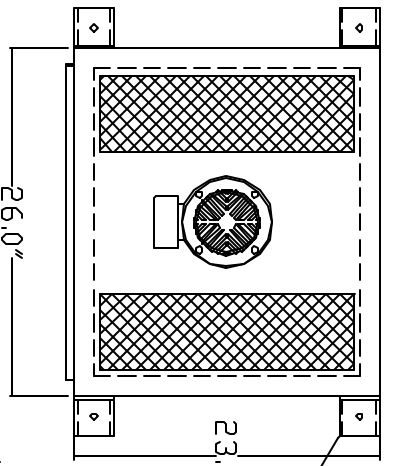

- AIR VOLUME: 500-800 CFM NOMINAL
- MOTOR: 1.5 HP TEFC, 3450 RPM
- VOLTAGE 115/230/1/60
- BLOWER: DIRECT DRIVE, NON-OVERLOADING, BACKWARD INCLINED ALUMINUM WHEEL
- CABINET CONSTRUCTION: 14/16 GA, WELDED STEEL
- FILTRATION: 3 STAGE
2" IMPINGER
- 1" ALUMINUM WASHABLE PRE-FILTER
HIGH EFFICIENCY EXTENDED SURFACE
100% SYNTHETIC FILTER MEDIA
(143.63 SQ. FT.)
- MAGNEHELIC GAGE